

P/N

REVISIONS

REV	DESCRIPTION	DATE	APPD

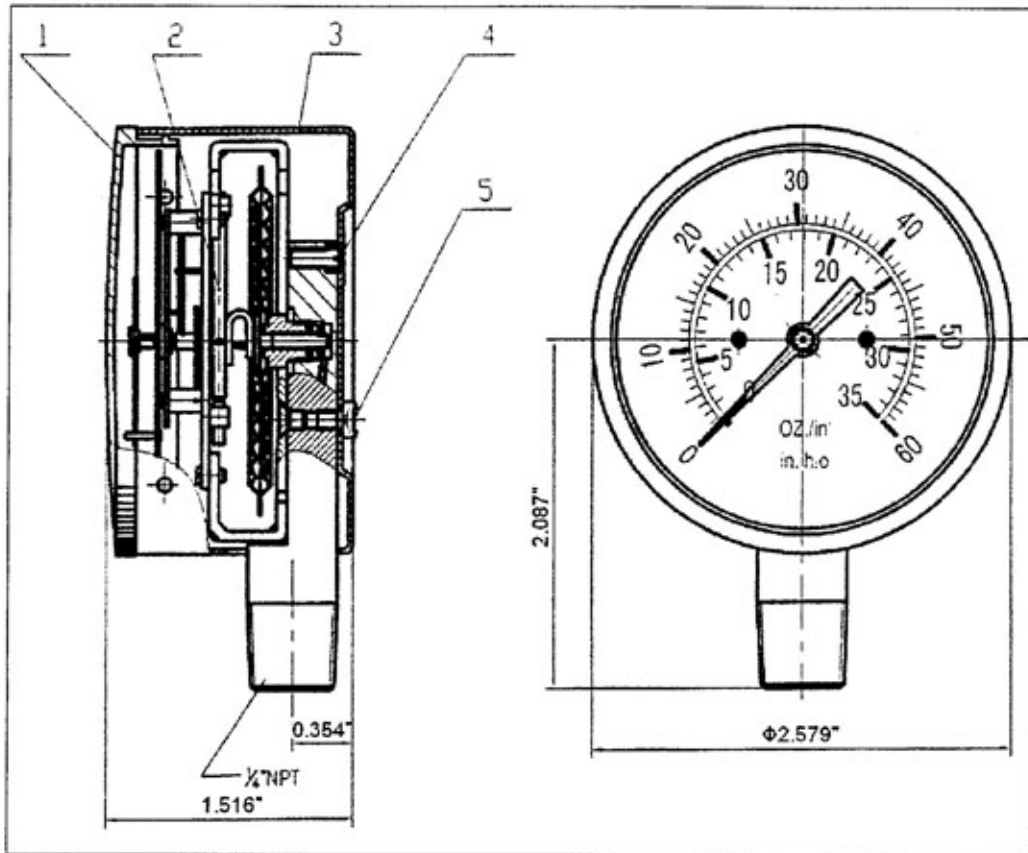

Technical Specification:

1. All fasteners should be tightened in place after assembly; any loosen fastener was not allowed.
2. Pointer operation should be smoothly; any uneven movement was not allowed. Pointer gap between the Indicator Plate should be on 0.04"~0.12".
3. Pointer tip should kept sharp and clean, Calibration and Numeral on the Indicator Plate should clear and clean. All parts out shape can not allowed any scratch or damaged.

5	GB/T820-2000	Screw	2	Stainless steel		
4	YE-65-002	Self-adhesive paper	1	Paper		
3	YE-65-006	Case	1	Chrome plated steel		
2	YE-65-100	Parts of internal	1	Brass	RB	
1	YE-65-011	Window	1	Plastic		
NO	ITEM NO	COMPONENTS	QUANTITY	MATERIAL	FINISH	NOTE

TOLERANCES UNLESS OTHERWISE SPECIFIED

	INCHES	METRIC
DECIMALS	.X ±0.1	X ±0.5
	.XX ±0.01	.X ±0.2
	.XXX ±0.005	.XX ±0.1
FRACTIONS	±1/16	
	ANGLE:±0.5°	ANGLE:±0.5°

FIRST ANGLE PROJECTION:

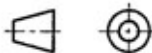

DRAWN BY: John Yu

APPROVED BY:

CUSTOMER:

JB Products, Inc.

6851 Enterprise Drive South Bend Indiana 46628

35oz. Gas Tester Gauge

Replacement Gauge for P/N 1515